



# LOGIC COMBI.

C24 C30 C35

HIGH EFFICIENCY COMBINATION BOILERS.



## KEY FEATURES

- Easy to see pressure gauge
- Large backlit display with user friendly controls
- Low lift weight (starting from 28.9kg)
- Low component count maximising reliability
- Pre-heat function
- 75mm deep translucent condensate siphon
- Fully modulating operation to low outputs
- Automatic bypass
- Four optional language user instructions\*
- Visually impaired user fascia option

## RELIABLE

- Energy Saving Trust endorsed
- Flexible warranty
- Boiler frost protection
- Built-in, easy to use filling loop
- Simple diverter valve design
- Two stage flame sensing for greater reliability
- Latest generation Honeywell gas valve

## EASY TO INSTALL

- Compact cupboard fit
- Fast fix flues
- Wide range of additional flueing options
- Easy access to PRV and AAV
- Preformed copper tails
- Pre-wired mains lead (2m)
- Universal condensate connection
- Stand off kit including piping option
- Compatible with a range of additional controls inc. weather compensation
- LPG conversion kit available for 24 kW & 30 kW boilers



Compact



LPG Conversion Kit\*\*



Frost Protection



Flue Variants



NOx Class 5



# CLEARANCES & DIMENSIONS.

Height: 700mm  
Width: 395mm  
Depth: 278mm

DIMENSIONS IN MM

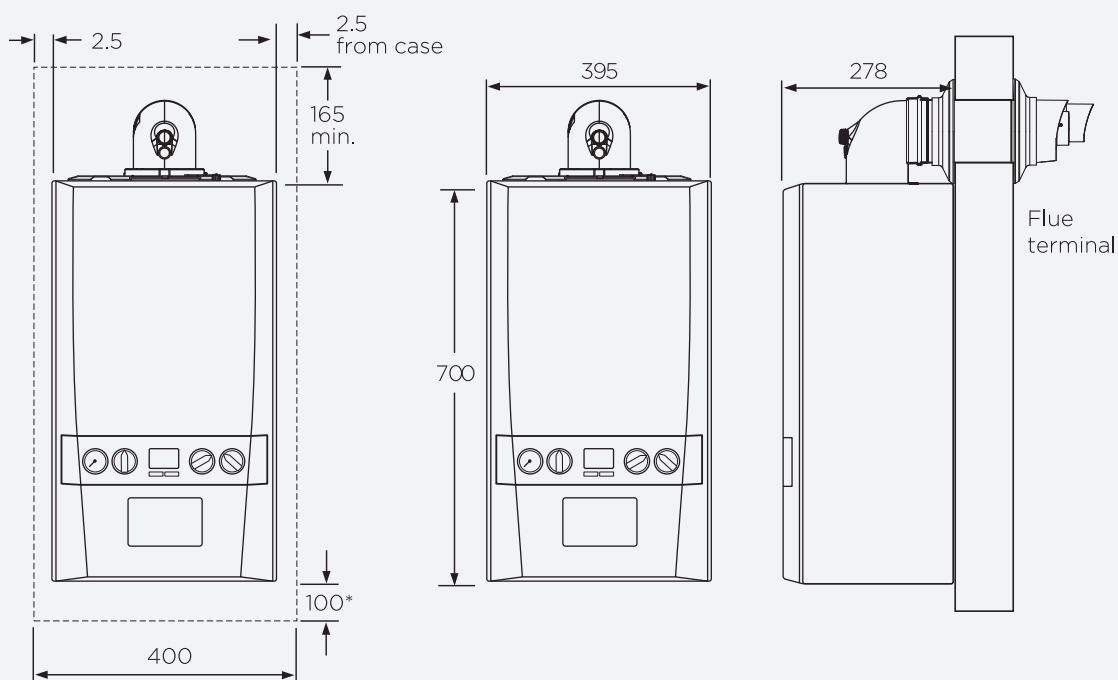

Note: The minimum front clearance when built in to a cupboard is 5mm from the cupboard door but 450mm overall clearance with the cupboard door open is required for servicing. \*Bottom clearance after installation can be reduced to 5mm. However, 100mm is required for servicing.

# TECHNICAL SPECIFICATIONS.

BOILER MODEL	C24	C30	C35
Weight (packaged) kg	33.7	33.8	33.9
Max installation weight kg	28.9	29.0	29.1
CH output (kW) min/max mean 70°C	4.8 - 24.2	6.1 - 24.2	7.1 - 24.2
CH output (kW) min/max mean 40°C	5.1 - 25.6	6.4 - 25.6	7.5 - 25.6
DHW output (kW) max	24.2	30.3	35.3
DHW flow rate l/min. 35°C rise	9.9	12.4	14.5
SEDBUK rating (2005) %	91.1	91.1	91.1
SEDBUK rating (2009/2012) %	89.6	89.6	89.6
NOx classification	CLASS 5	CLASS 5	CLASS 5
Convert to LPG	Yes	Yes	No
Max horizontal flue*	9m	8m	6m
Max vertical flue*	7.5m	7.5m	7.5m
Powered vertical flue†	22m	22m	22m
Condensing boiler	Yes	Yes	Yes
Seasonal space heating efficiency class	A	A	A
Rated heat output kW	24	24	24
Seasonal space heating energy efficiency $\eta_s$ %	94	94	94
Sound power level, indoors L <sub>WA</sub> dB	48	46	44
Water heating energy efficiency class	A	A	A

Available Flue Extensions 0.5m, 1m and 2m. Multiple flue kits available.

\* Each 90° elbow used is at the expense of 1000mm of straight flue run, and each 45° elbow is used at the expense of 600mm of straight flue run.

† Typical combined primary and secondary length. See installation instructions for more details. Note: The Flue Deflector Kit is used at the expense of 1000mm of straight flue run.